

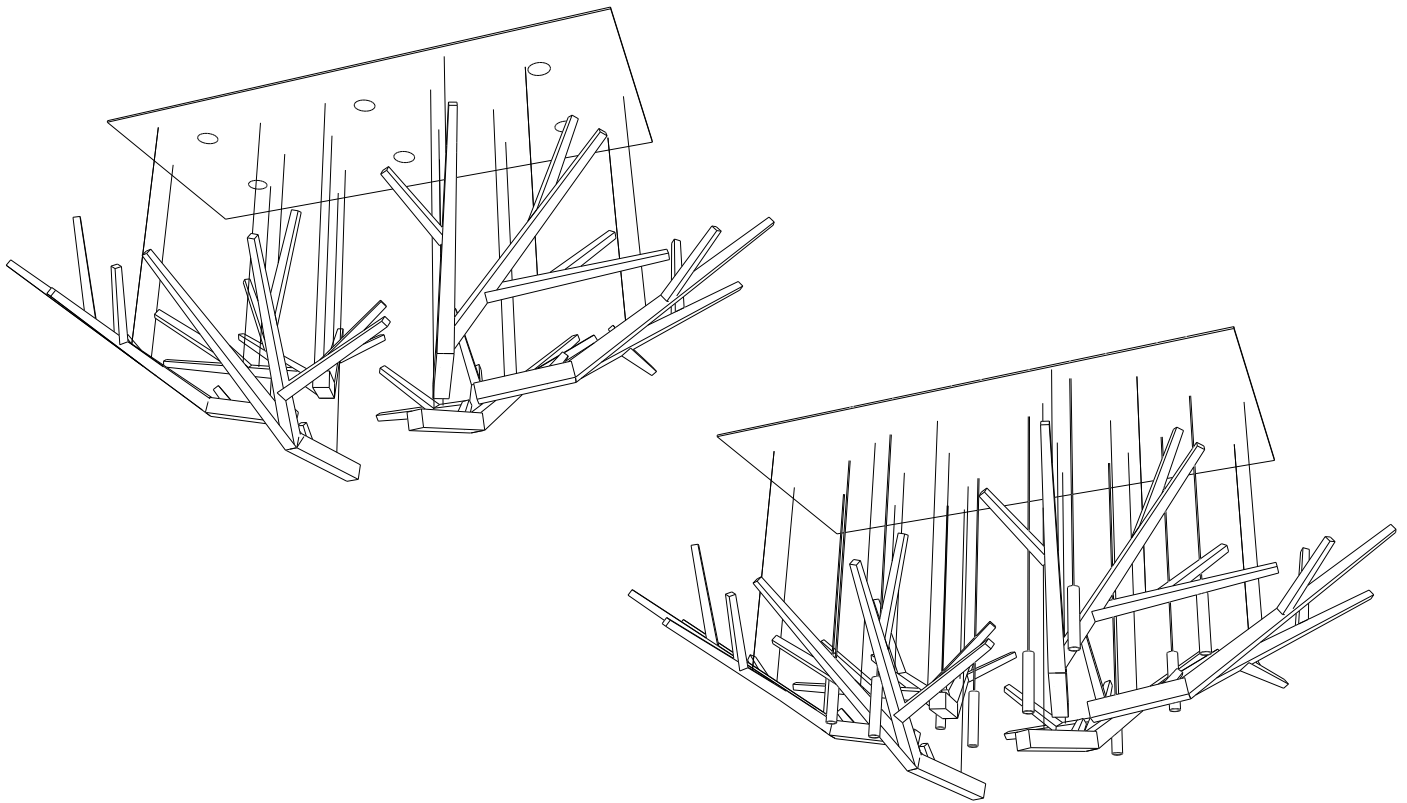

The Bosk branch chandelier is a light sculpture inspired by the symmetries of the forest. Either illuminated from above by recessed led lights or lit from within by ambient LED pendants, Bosk becomes a radiant feature, evoking nature in your space.

Bosk is crafted from solid wood and hand-finished to a satin sheen, allowing the natural warmth of the wood's colour and grain to be fully expressed.

As with all of our wood chandeliers, the Bosk branch chandelier is carefully handcrafted with attention paid to creating crisp joinery and a finish that is compelling to the eye and the touch.



## BOSK BRANCH CHANDELIER

### Description:

Sculptural wood luminaire with branching forms, ideal over tables, bars, stairways and in lobbies. Lit with canopy mounted or pendant LED lamps

### Details:

Hanging elements: alder, fir or walnut natural oil and wax finish. Custom woods available.

Canopy: white, silver, or black powder coated aluminum, custom colours available.

Suspension: skirted plate direct to ceiling substrate. Drop is to specification.

### Environmental:

- low emitting materials (natural oil and wax finish)
- energy efficient LEDs

### Regulatory Compliance:

All products are inspected and accepted by QAI Laboratories or CSA International prior to shipment.

Final acceptance of the approval mark is subject to the requirements of the local Authority Having Jurisdiction.

### BOSK 72 x 42 - CANOPY MOUNTED LIGHTS

Dimensions: 72" x 42" x 23"

Drop: to specification, measurement required

Lamping: 6 x 9W flush mounted LED lights (3000K, 4000K or 5000K), 750LM ea.

Power supply: dimmable driver 120V input

Weight: approx 55lb.

Retail: \$6745 CAD

**Ordering code:**

**BO-CM\_A** (alder)

**BO-CM\_F** (fir)

**BO-CM\_W** (walnut)

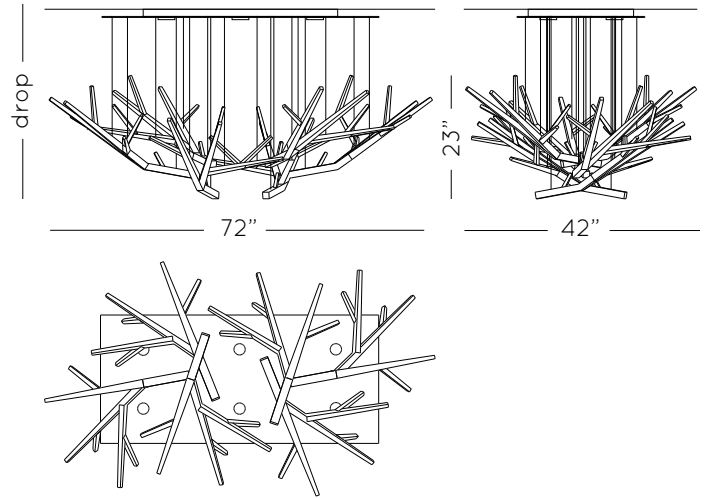

### BOSK 72 x 42 - PENDANT LIGHTS

Dimensions: 72" x 42" x 23"

Drop: to specification, measurement required

Lamping: 10 x 4W warm white (3000K) LED G4 bi-pin lights, 300-340LM ea.

Power supply: ELV Dimmable Class 2 AC/DC switch mode. Input 120V AC 50/60Hz, Output 12V DC

Weight: approx 60lb.

Retail: \$8440 CAD

**Ordering code:**

**BO-P\_A** (alder)

**BO-P\_F** (fir)

**BO-P\_W** (walnut)

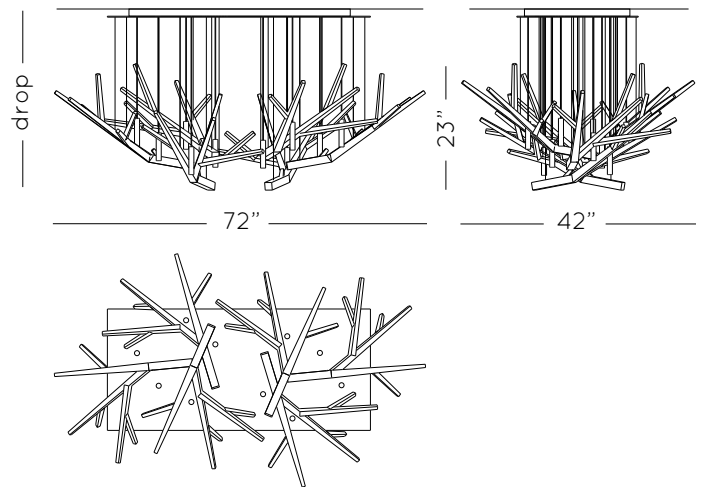

Typical lead times: 2-6 Weeks

**PRICING NOW INCLUDES CRATING & PACKAGING!**