

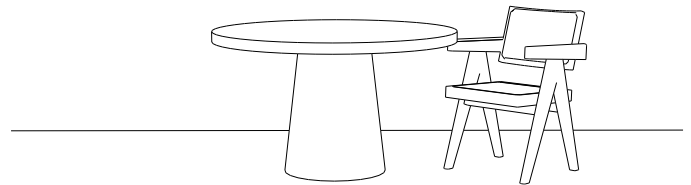

The Feld chandelier radiates a strong sculptural presence that makes it a perfect feature light to illuminate dining rooms, lobbies, foyers and stairwells.

As with all of Propellor's wooden light fixtures, the Feld chandelier is crafted from solid North American hardwoods, including walnut, oak, alder and ash. Feld chandeliers are hand-finished with a LEED compliant, low VOC, non-toxic, natural oil finish that brings the beauty of the wood grain to life.

The shape, size, wood type and finish of the Feld wood chandelier can be customized and tailored to suit the specifications of your project. Contact us to discuss how we can design the ideal Feld chandelier for your project.

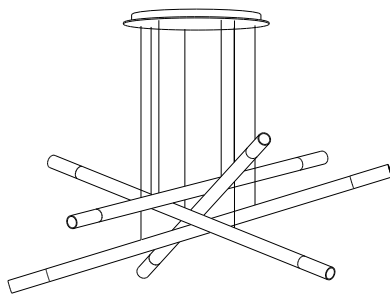
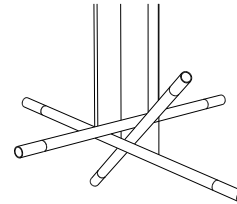
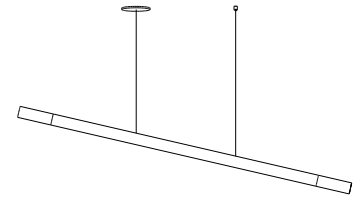
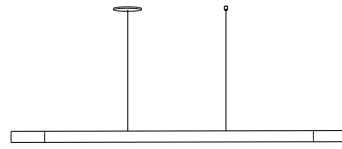
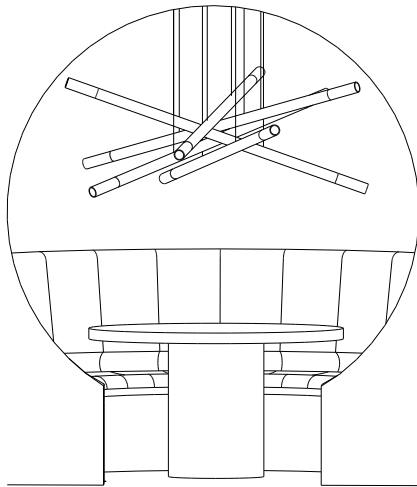

## FELD MODERN WOOD CHANDELIER

### Description:

Sculptural wood luminaire with radiating linear elements, ideal over tables, bars, stairwells and in lobbies.

### Details:

Hanging elements: walnut, oak, alder or ash, natural oil and wax finish. Custom woods available.

Canopy: white, silver, or black powder coated aluminum, custom colours available.

Suspension: Feld 1: 5"Ø canopy to junction box, cable to ceiling substrate. Feld 2-5: skirted plate direct to ceiling substrate. Drop is to specification.

### Environmental:

- low emitting materials (natural oil and wax finish)
- energy efficient LED lamping

### Lamping:

Warm white (3000K) dimmable bi-pin (G4 - GY6.35) LED lamps.

Power supply: ELV Dimmable Class 2 AC/DC switch mode. Input 120V AC 50/60Hz, Output 12V DC

### Regulatory Compliance:

All products are inspected and accepted by QAI Laboratories or CSA International prior to shipment.

Final acceptance of the approval mark is subject to the requirements of the local Authority Having Jurisdiction.

# propellor

## Standard Configurations

### FELD 1

Dimensions: Ø2" L: 60"

Drop: to specification, measurement required

Lamping: 2 x 2W (35W equiv.) warm white (3000K)

LED G4 bi-pin lights, 275LM ea.

Power supply: dimmable 12W, 12V driver 120V input

Weight: approx 6lb.

Retail: \$2190 CAD

#### Ordering code:

FE1\_A (ash)

FE1\_RA (red alder)

FE1\_W (walnut)

FE1\_WO (white oak)

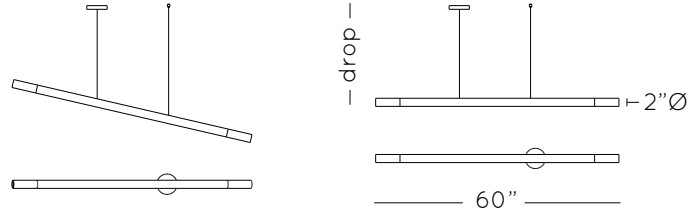

### FELD 2

Dimensions: Ø60" H: 23"

Drop: to specification, measurement required

Lamping: 4 x 2W (35W equiv.) warm white

(3000K) LED G4 bi-pin lights, 275LM ea.

Power supply: dimmable 60W driver 120V input

Weight: approx 22lb.

Retail: \$5215 CAD

#### Ordering code:

FE2\_A (ash)

FE2\_RA (red alder)

FE2\_W (walnut)

FE2\_WO (white oak)

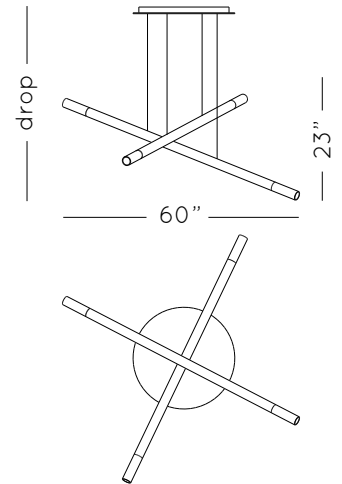

### FELD 3

Dimensions: Ø60" H: 23"

Drop: to specification, measurement required

Lamping: 6 x 2W (35W equiv.) warm white

(3000K) LED G4 bi-pin lights, 275LM ea.

Power supply: dimmable 60W driver 120V input

Weight: approx 28lb.

Retail: \$6765 CAD

#### Ordering code:

FE3\_A (ash)

FE3\_RA (red alder)

FE3\_W (walnut)

FE3\_WO (white oak)

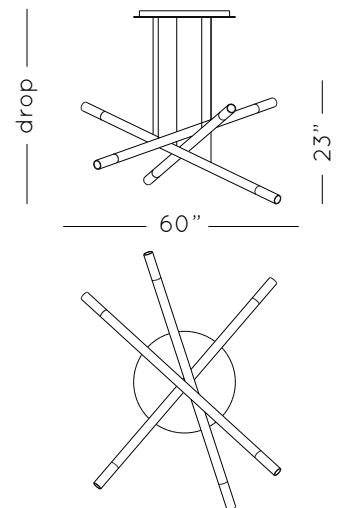

Typical lead times: 2-6 Weeks

\*prices reflect standard models, please contact us for enquiries regarding customisation.

www.propellor.ca 1247 Cartwright Street, Vancouver, BC 604 682 6665 studio@propellor.ca

# propellor

## Standard Configurations

### FELD 4

Dimensions: Ø60" H: 23"

Drop: to specification, measurement required

Lamping: 8 x 2W (35W equiv.) warm white  
(3000K) LED G4 bi-pin lights, 275LM ea.

Power supply: dimmable 60W driver 120V input

Weight: approx 34lb.

Retail: \$8675 CAD

#### Ordering code:

FE4\_A (ash)

FE4\_RA (red alder)

FE4\_W (walnut)

FE4\_WO (white oak)

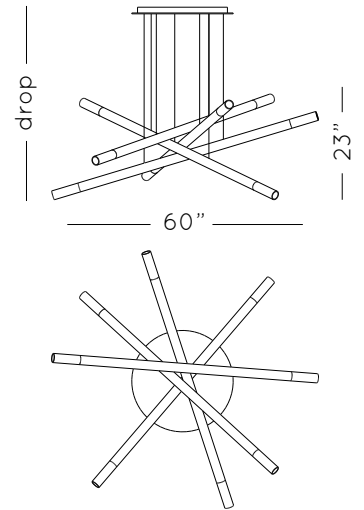

---

### FELD 5

Dimensions: Ø60" H: 23"

Drop: to specification, measurement required

Lamping: 10 x 2W (35W equiv.) warm white  
(3000K) LED G4 bi-pin lights, 275LM ea.

Power supply: dimmable 60W driver 120V input

Weight: approx 40lb.

Retail: \$9945 CAD

#### Ordering code:

FE5\_A (ash)

FE5\_RA (red alder)

FE5\_W (walnut)

FE5\_WO (white oak)

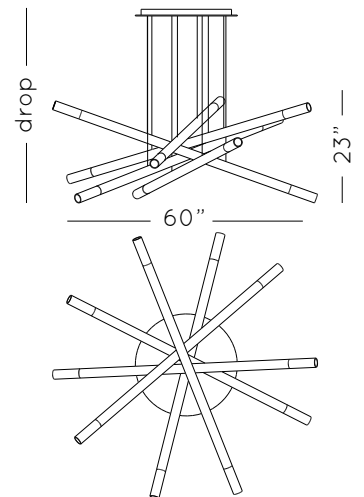

Typical lead times: 2-6 Weeks

\*prices reflect standard models, please contact us for enquiries regarding customisation.

www.propellor.ca 1247 Cartwright Street, Vancouver, BC 604 682 6665 studio@propellor.ca